

SMT-Präzisions-Buchsenleisten RM 1,27mm, liegend, 1-reihig SMT Precision Female Headers, 1.27mm Pitch, Horizontal, Single Row

Technische Daten / Technical Data

Isolierkörper <i>Insulator</i>	Thermoplast, nach UL94 V-0 <i>Thermoplastic, rated UL94 V-0</i>
Kontaktmaterial <i>Contact Material</i>	Hülse: Messing gedreht Feder: 3-Lamellen-Clip, Beryllium-Kupfer <i>Sleeve: screw machined brass Clip: 3-Finger-Clip, Beryllium-Copper</i>
Kontaktoberfläche <i>Contact Surface</i>	Lt. Oberflächenoptionen, über Ni (1,3 ... 2,5µm) <i>Acc. to options (see below), over Ni (1.3 ... 2.5µm)</i>
Durchgangswiderstand <i>Contact Resistance</i>	< 20 mΩ
Isolationswiderstand <i>Insulation Resistance</i>	> 1000 MΩ
Spannungsfestigkeit <i>Test Voltage</i>	500 V RMS
Nennspannung <i>Voltage Rating</i>	100 V RMS / 150 V DC
Nennstrom <i>Current Rating</i>	1 A
Temperaturbereich <i>Temperature Range</i>	-55 °C ... +125 °C
Verarbeitung <i>Processing</i>	Reflow-Lötverfahren <i>Reflow soldering</i>

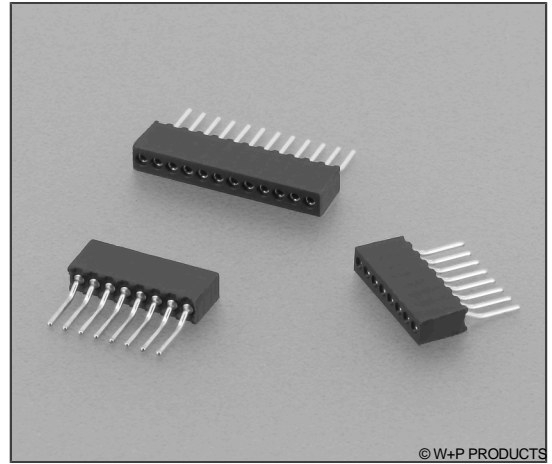

© W+P PRODUCTS

Einsetzbar für Rundstifte Ø0,40-0,48mm.
Accept Ø0.40-0.48mm round pins.

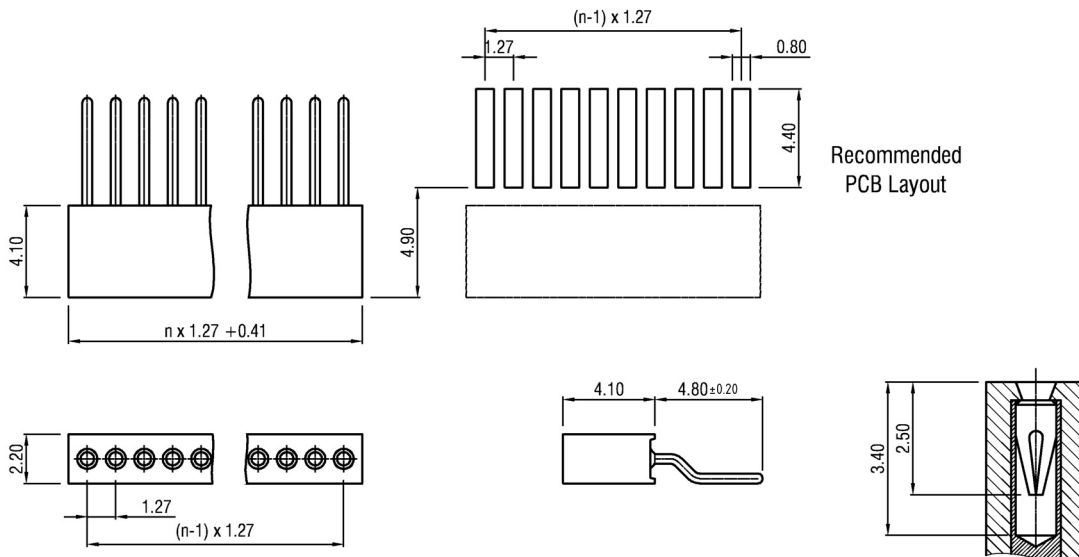

Recommended
PCB Layout

Series	Contacts*	Sleeve Plating	Clip Plating*	Packaging
1534	02 02-50 Einreihig Single row	50 50 Hülse verzinkt Tin plated sleeve	00 00 Feder vergoldet Gold plated clip 10 Feder 0,25µm Gold (Option) 0.25µm gold plated clip (Option) 30 Feder 0,75µm Gold 0.75µm gold plated clip	ST ST TR (Option)

* Dies ist ein **Bestellbeispiel** -
bitte durch Ihre Spezifikationen ersetzen.
* This is an **order example** -
please replace by your specifications.

Lieferformen / Packaging Options:

ST In Stangen ohne Pick&Place-Pads / In tubes w/o Pick&Place-Pads
TR (Option) Tape & Reel ohne PP-Pads / Tape & Reel w/o PP-Pads

Informationen zum Reflow-Lötverfahren Reflow Soldering Information

Reflow-Lötempfehlung für kurze Lötzeiten

Die Bauteile sollten gemäß folgendem Temperatur-Profil in Anlehnung an die IPC/JEDEC J-STD-020C für bleifreies Löten im Reflow-Verfahren verarbeitet werden (Maximalwerte).

Profileigenschaft	Kennwert
Temperatur Minimum T_{Smin}	150 °C
Temperatur Maximum T_{Smax}	200 °C
Dauer $T_{Smin} - T_{Smax}$	60 – 180s
Temperatur Lötbereich T_L	217 °C
Verweildauer oberhalb T_L	60 – 180s
Ramp-Up Rate $T_{Smax} - T_P$	max. 3 °C / s
Höchsttemperatur T_P	260±5 °C
Dauer Höchsttemperatur	20 – 40s
Ramp-Down Rate $T_{Pmax} - T_{Smin}$	6 °C / s
Dauer 25 °C – Höchsttemperatur T_P	max. 8m

Reflow Soldering Recommendation For Shorter Peak Times

Items should be soldered according to IPC/JEDEC J-STD-020C temperature profile for leadfree reflow soldering (maximum values).

Profile Feature	Key Values
Minimum Temperature T_{Smin}	150 °C
Maximum Temperatur T_{Smax}	200 °C
Duration $T_{Smin} - T_{Smax}$	60 – 180s
Soldering Range Temperature T_L	217 °C
Duration above T_L	60 – 180s
Ramp-Up Rate $T_{Smax} - T_P$	max. 3 °C / s
Peak Temperature T_P	260±5 °C
Duration Peak Temperature	20 – 40s
Ramp-Down Rate $T_{Pmax} - T_{Smin}$	6 °C / s
Duration 25°C - Peak Temp. T_P	max. 8min

