

## Crimp Rast Wannenstiftleisten RM 2.5mm, gerade/gewinkelt, 1-/2-reihig Friction Lock Pin Headers 2.5mm Pitch, Straight/Right-Angled, Single/Double Row

### Technische Daten / Technical Data

Gehäuse	Thermoplast, nach UL94 V-0
Shell	Thermoplastic, rated UL94 V-0
Isolierkörper	Thermoplast, nach UL94 V-0
Insulator	Thermoplastic, rated UL94 V-0
Kontaktmaterial	Kupferlegierung
Contact Material	Copper alloy
Kontaktoberfläche	Zinn über Nickel
Contact Surface	Tin plated over nickel
Durchgangswiderstand	< 20 mΩ
Contact Resistance	< 20 mΩ
Isolationswiderstand	> 1000 MΩ
Insulation Resistance	> 1000 MΩ
Spannungsfestigkeit	1500 V AC
Test Voltage	1500 V AC
Nennspannung	250 V AC/DC
Voltage Rating	250 V AC/DC
Nennstrom	6 A
Current Rating	6 A
Temperaturbereich	-25 °C ... +105 °C
Temperature Range	-25 °C ... +105 °C
Verarbeitung	Wellenlötverfahren
Processing	Wave soldering

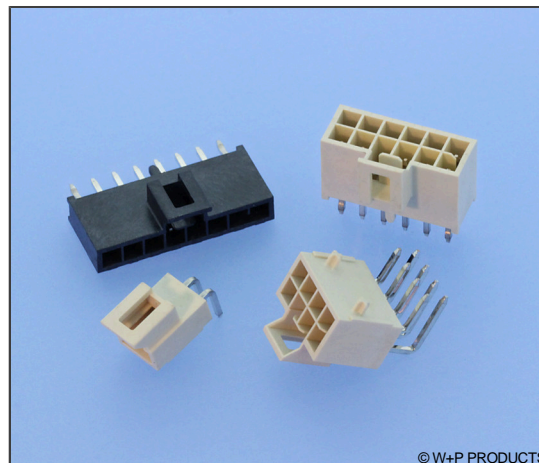

© W+P PRODUCTS

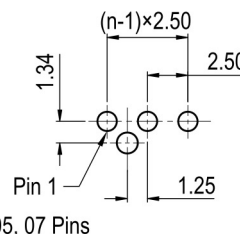
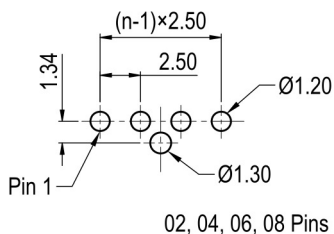
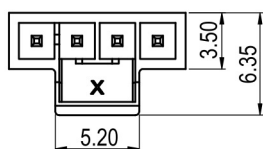

**Recommended PCB Layouts**  
**Recommended PCB Thickness 1.6~2.4mm**

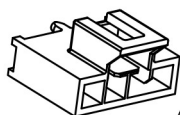
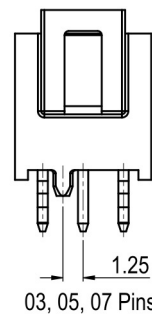
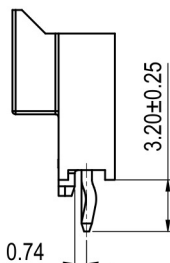
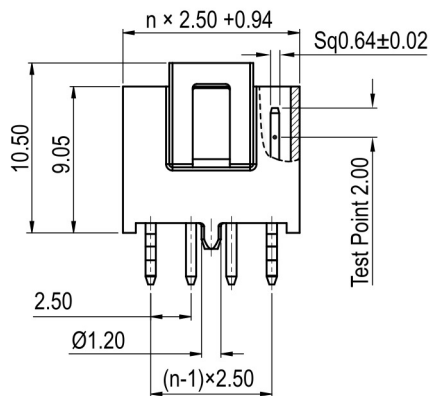

Key A  
(black housing)

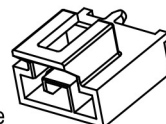

Key B  
(natural white housing)

# 530

## Crimp Rast Wannenstiftleisten RM 2.5mm, gerade/gewinkelt, 1-/2-reihig Friction Lock Pin Headers 2.5mm Pitch, Straight/Right-Angled, Single/Double Row

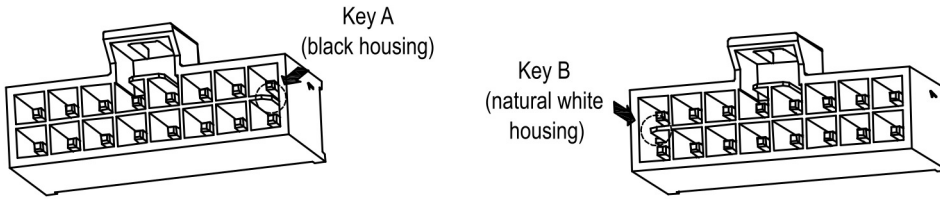
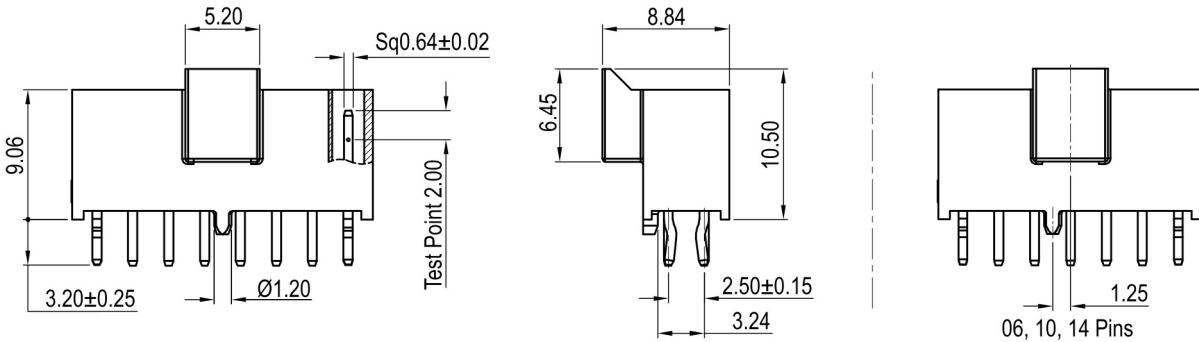
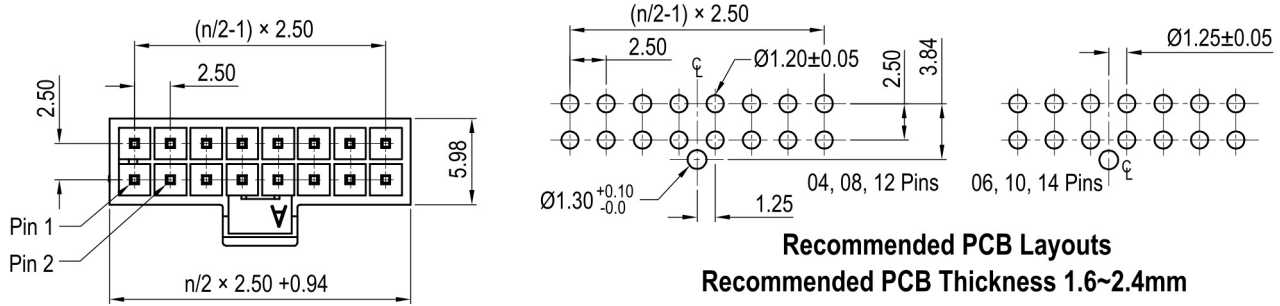

Series	Contacts*	Type	Rows*	Key*	Plating
<b>530</b>	<b>06</b> 02-08 Einreihig Single row 04-16 Zweireihig Double row	<b>3</b> 3 Stiftleiste gerade Box header, vertical	<b>2</b> 1 Einreihig Single row 2 Zweireihig Double row	<b>1</b> 1 Key A, schwarz Key A, black 2 Key B, naturweiß Key B, natural	<b>50</b> 50 Sn

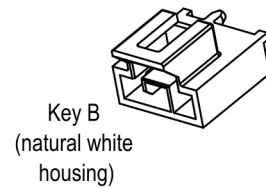
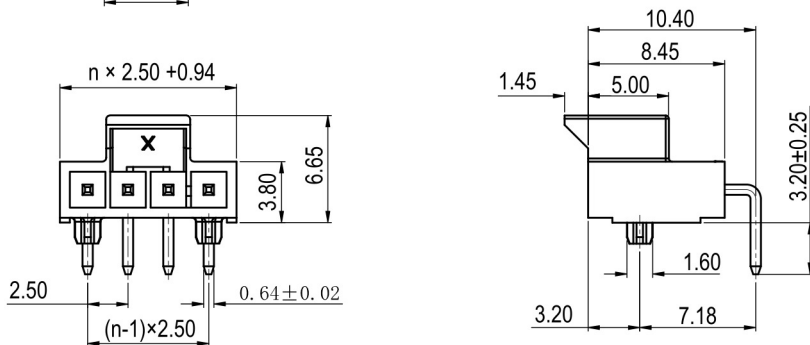
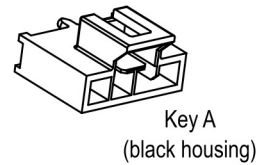
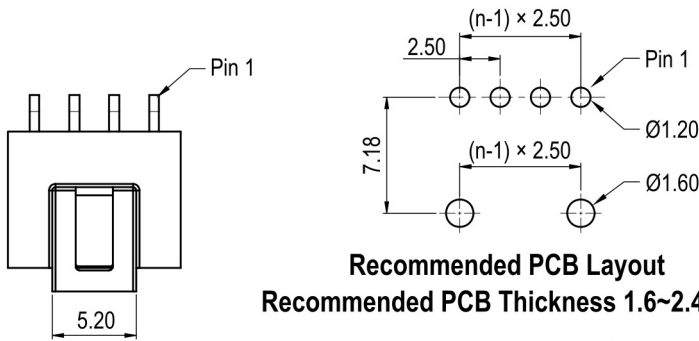

## Crimp Rast Wannenstiftleisten RM 2.5mm, gerade/gewinkelt, 1-/2-reihig Friction Lock Pin Headers 2.5mm Pitch, Straight/Right-Angled, Single/Double Row

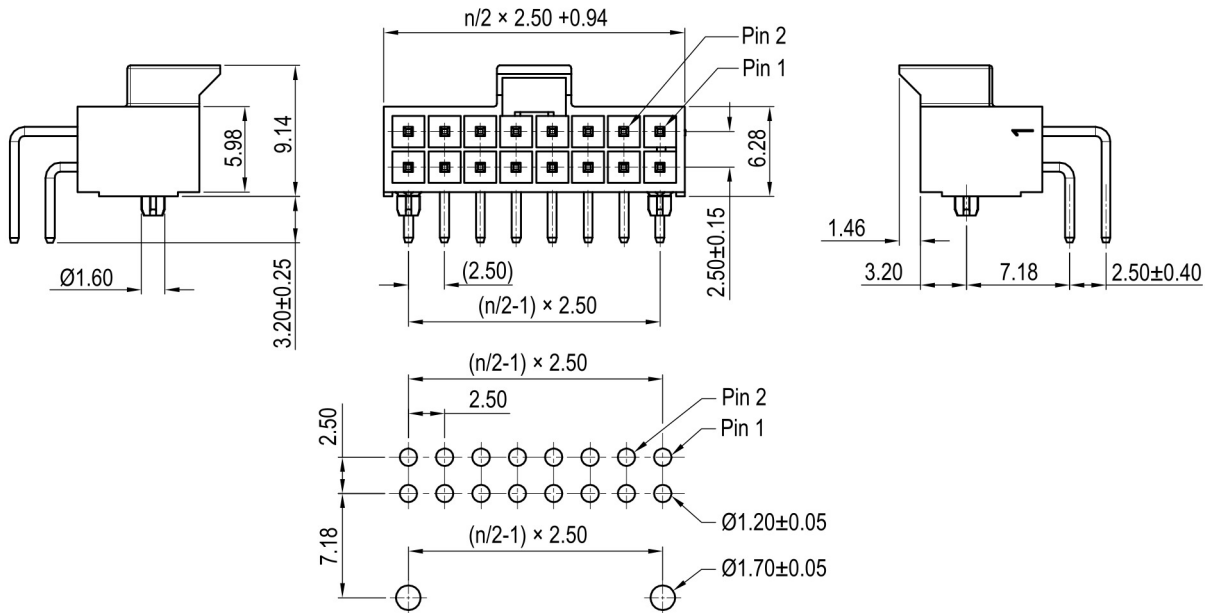
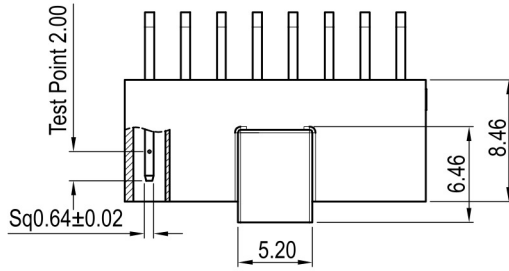

**Recommended PCB Layouts**  
**Recommended PCB Thickness 1.6~2.4mm**

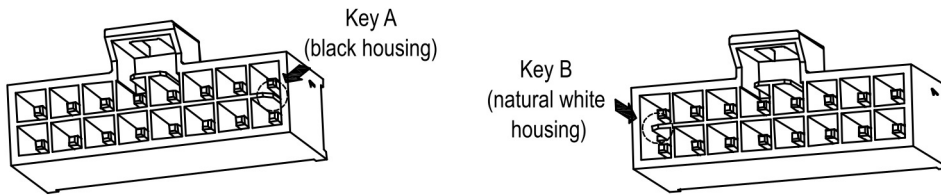

Series	Contacts*	Type	Rows*	Key*	Plating
<b>530</b>	<b>12</b> 02-08 Einreihig Single row 04-16 Zweireihig Double row	<b>4</b> 4 Stiftleiste gewinkelt Box header, horizontal	<b>2</b> 1 Einreihig Single row 2 Zweireihig Double row	<b>1</b> 1 Key A, schwarz Key A, black 2 Key B, naturweiß Key B, natural	<b>50</b> 50 Sn

\* Dies ist ein **Bestellbeispiel** -  
bitte durch Ihre Spezifikationen ersetzen.  
\* This is an **order example** -  
please replace by your specifications.