

Crimp-Rast-Stift-/Buchsenleisten mit Verriegelung RM 2,50mm Friction Lock Headers / Crimp Housings, Locking Type, 2.50mm Pitch

Technische Daten / Technical Data

Isolierkörper <i>Insulator</i>	Thermoplast, nach UL94 V-0 <i>Thermoplastic, rated UL94 V-0</i>
Kontaktmaterial <i>Contact Material</i>	Kupferlegierung <i>Copper alloy</i>
Kontaktfläche <i>Contact Surface</i>	Zinn über Nickel <i>Tin plated over nickel</i>
Aderquerschnitt <i>Applicable wire Gauge</i>	AWG 26 ~ 22
Durchgangswiderstand <i>Contact Resistance</i>	< 10 mΩ
Isolationswiderstand <i>Insulation Resistance</i>	> 1000 MΩ
Spannungsfestigkeit <i>Test Voltage</i>	1 kV AC
Nennspannung <i>Voltage Rating</i>	250 V AC/DC
Nennstrom <i>Current Rating</i>	3 A AC/DC
Temperaturbereich <i>Temperature Range</i>	-25 °C ... +85 °C

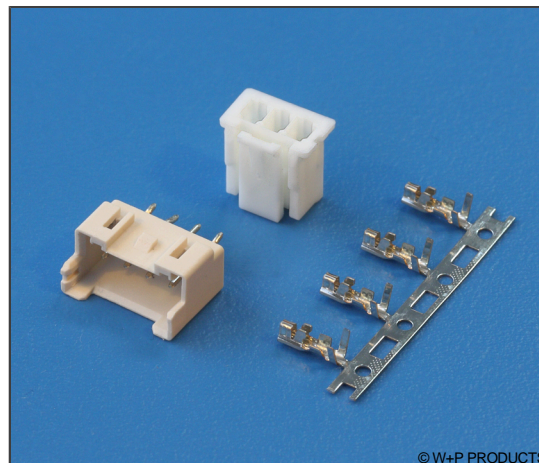

© W+P PRODUCTS

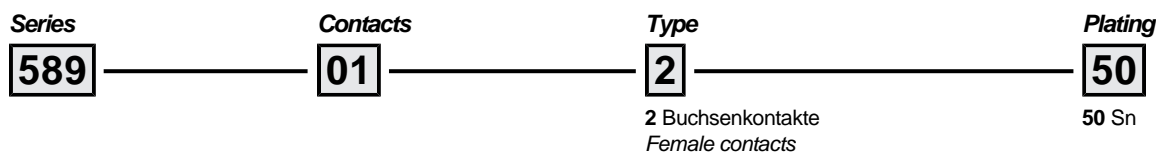
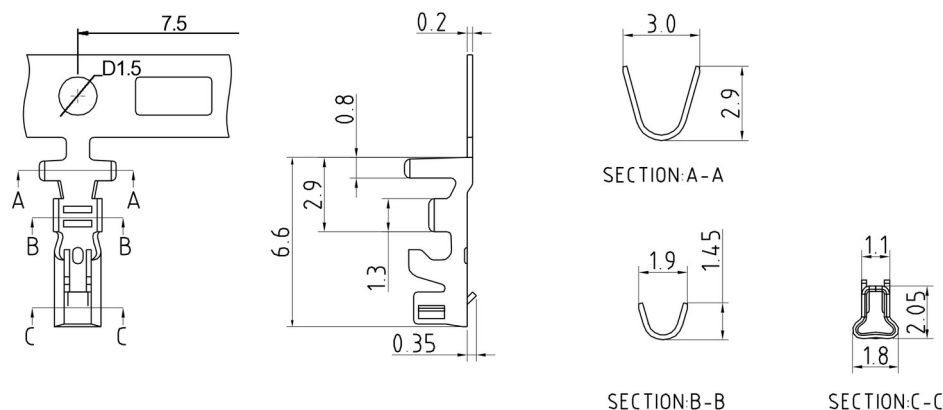
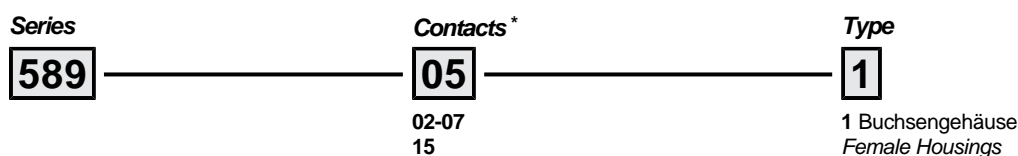
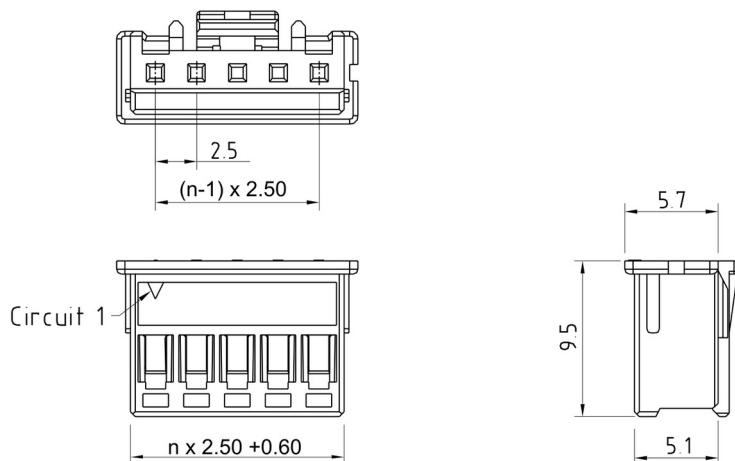

589

Crimp-Rast-Stift-/Buchsenleisten mit Verriegelung RM 2,50mm Friction Lock Headers / Crimp Housings, Locking Type, 2.50mm Pitch

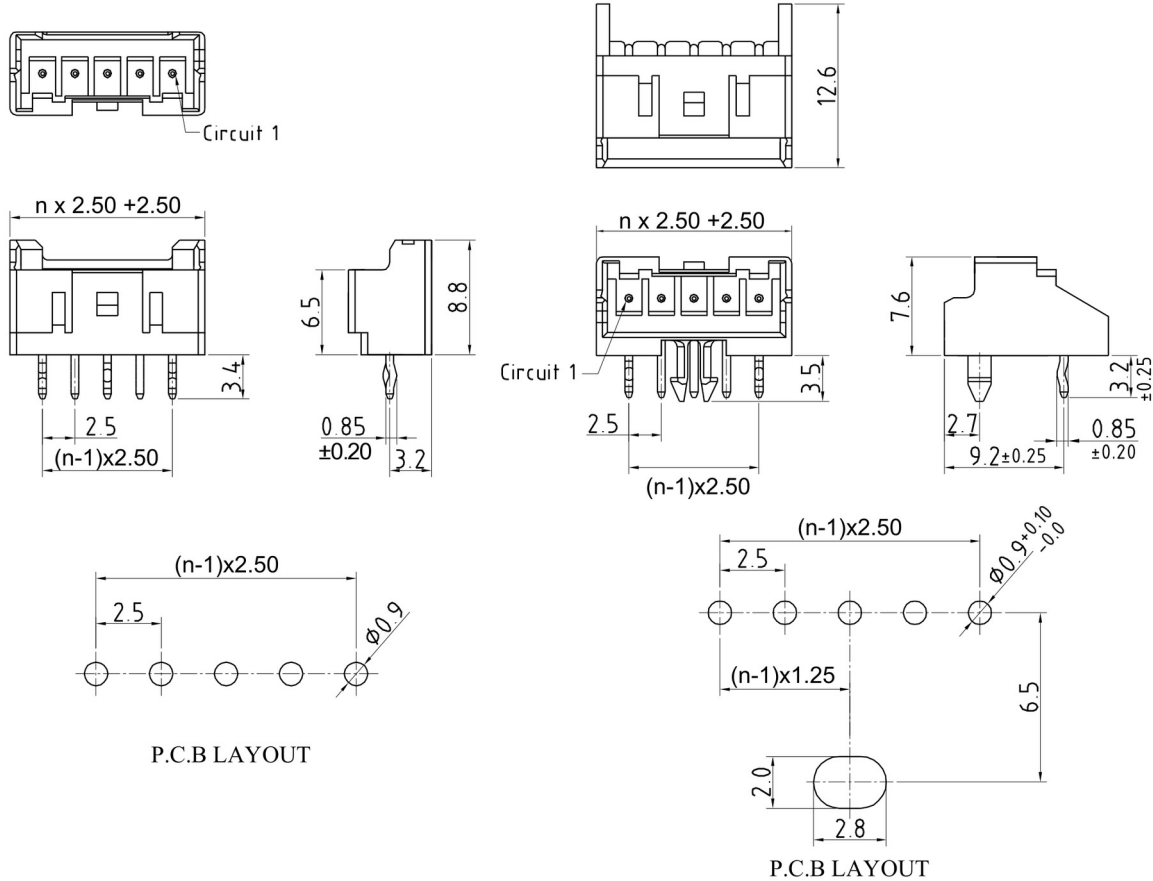

Series	Contacts*	Type	Board Lock	Plating
589	05 02-07 15	3 3 Stiftheisten gerade Pin headers straight	0 0 Ohne Board Lock W/o Board Lock	50 50 Sn
Series	Contacts*	Type	Board Lock*	Plating
589	05 02-07 15	4 4 Stiftheisten gewinkelt Pin headers right-angled	1 0 Ohne Board Lock W/o Board Lock 1 Mit Board Lock With Board Lock	50 50 Sn

* Dies ist ein **Bestellbeispiel** -
bitte durch Ihre Spezifikationen ersetzen.
* This is an **order example** -
please replace by your specifications.