

Stiftleisten RM 1,27mm, gerade/gewinkelt, 1-/2-reihig – Rundstifte 0,42mm Pin Headers, 1.27mm Pitch, Straight/Right-Angled, Single/Double Row – 0.42mm Round Pins

Technische Daten / Technical Data

Isolierkörper <i>Insulator</i>	Thermoplast, nach UL94 V-0 <i>Thermoplastic, rated UL94 V-0</i>
Kontaktmaterial <i>Contact Material</i>	Rundstift Ø0,42mm, Kupferlegierung <i>Ø0,42mm round pin, copper alloy</i>
Kontaktoberfläche <i>Contact Surface</i>	Lt. Oberflächenoptionen, über Ni <i>Acc. to options (see below), over Ni</i>
Durchgangswiderstand <i>Contact Resistance</i>	< 20 mΩ
Isolationswiderstand <i>Insulation Resistance</i>	> 1000 MΩ
Spannungsfestigkeit <i>Test Voltage</i>	500 V AC
Nennstrom <i>Current Rating</i>	1 A
Temperaturbereich <i>Temperature Range</i>	-55 °C ... +125 °C
Verarbeitung <i>Processing</i>	Wellen- oder Reflow-Lötverfahren <i>Wave or reflow soldering</i>

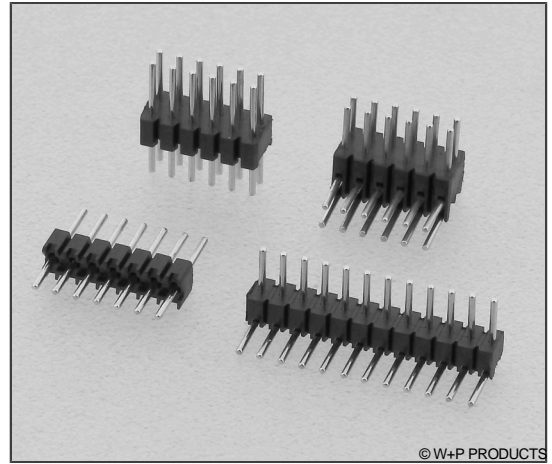

© W+P PRODUCTS

Passende Buchsenleisten:
Compatible Female Headers:
155 etc.
Weitere siehe Kapitel B
Please see ch. B for more

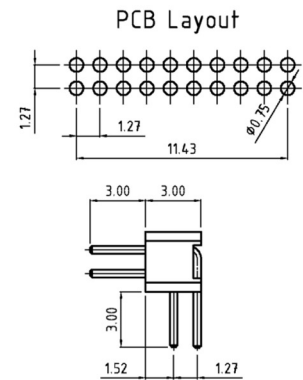
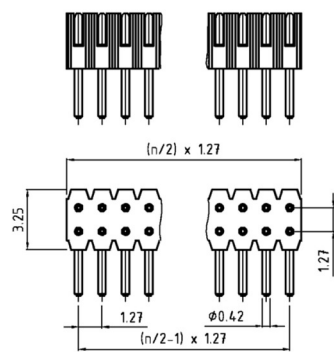
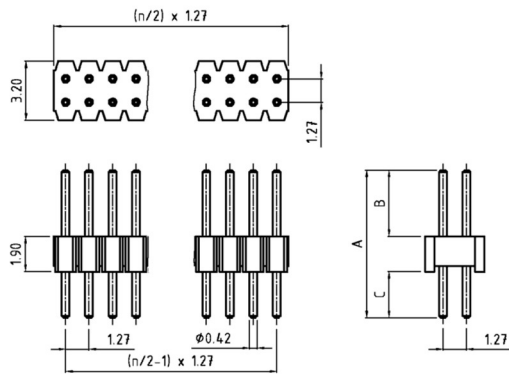
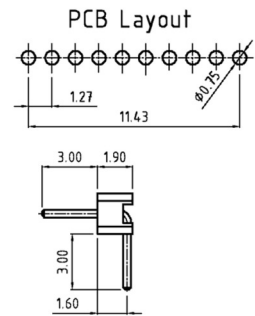
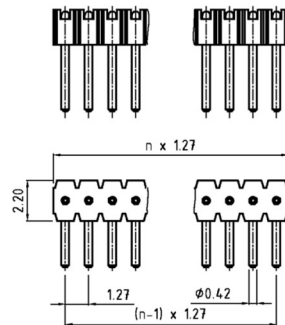
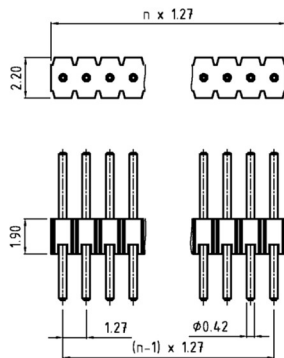

Series	Dimensions*	Type*	Contacts*	Plating*
755	07	10	001	00
	07 A=8,00 B=3,60 C=2,50mm 09 A=8,60 B=4,20 C=2,50mm 13 A=12,90 B=8,50 C=2,50mm 91 Einreihig, gewinkelt (s. Zng.) <i>Single row, right-angled (as shown in dwg.)</i> 92 Zweireihig, gewinkelt (s. Zng.) <i>Dual row, right-angled (as shown in dwg.)</i> 99- Kundenspezifisch <i>Customer-specific</i>	10 Einreihig, gerade <i>Single row, straight</i> 11 Einreihig, gewinkelt (nur Dim. Code 91) <i>Single row, right-angled (dim. code 91 only)</i> 20 Zweireihig, gerade <i>Double row, straight</i> 92 Zweireihig, gewinkelt (s. Zng.) <i>Dual row, right-angled (as shown in dwg.)</i> 21 Zweireihig, gewinkelt (nur Dim. Code 92) <i>Double row, right-angled (dim. code 92 only)</i>	001-050 Einreihig <i>Single row</i> 002-100 Zweireihig <i>Double row</i>	00 Vergoldet <i>Gold plated</i> 50 Verzinkt <i>Tin plated</i>

* Dies ist ein **Bestellbeispiel** - bitte durch Ihre Spezifikationen ersetzen.
* This is an **order example** - please replace by your specifications.

Informationen zum Wellen-Lötverfahren

Wave Soldering Information

Empfehlungen für das Wellenlötverfahren

Recommendations for Wave Soldering

Die Bauteile sollten bei einer Lötbadtemperatur von 260°C in max. 5 Sekunden verlötet werden.

Empfohlenes Wellenlötprofil:



Reflow-Lötempfehlung für kurze Lötzeiten

Die Bauteile sollten gemäß folgendem Temperatur-Profil in Anlehnung an die IPC/JEDEC J-STD-020C für bleifreies Löten im Reflow-Verfahren verarbeitet werden (Maximalwerte).

Profileigenschaft	Kennwert
Temperatur Minimum T_{Smin}	150 °C
Temperatur Maximum T_{Smax}	200 °C
Dauer $T_{Smin} - T_{Smax}$	60 – 180s
Temperatur Lötbereich T_L	217 °C
Verweildauer oberhalb T_L	60 – 180s
Ramp-Up Rate $T_{Smax} - T_P$	max. 3 °C / s
Höchsttemperatur T_P	260±5 °C
Dauer Höchsttemperatur	20 – 40s
Ramp-Down Rate $T_{Pmax} - T_{Smin}$	6 °C / s
Dauer 25 °C – Höchsttemperatur T_P	max. 8m

Reflow Soldering Recommendation For Shorter Peak Times

Items should be soldered according to IPC/JEDEC J-STD-020C temperature profile for leadfree reflow soldering (maximum values).

Profile Feature	Key Values
Minimum Temperature T_{Smin}	150 °C
Maximum Temperatur T_{Smax}	200 °C
Duration $T_{Smin} - T_{Smax}$	60 – 180s
Soldering Range Temperature T_L	217 °C
Duration above T_L	60 – 180s
Ramp-Up Rate $T_{Smax} - T_P$	max. 3 °C / s
Peak Temperature T_P	260±5 °C
Duration Peak Temperature	20 – 40s
Ramp-Down Rate $T_{Pmax} - T_{Smin}$	6 °C / s
Duration 25°C - Peak Temp. T_P	max. 8min

